

PRIMASTAR CHOICES



Low Roof



High Roof



SWB Low Roof



SWB High Roof



LWB Low Roof



LWB High Roof

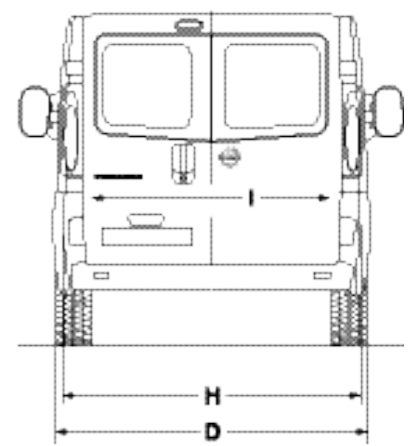

Dimensions (mm)	VAN				
	SWB Low	SWB High	LWB Low	LWB High	
Wheelbase	A	3098	3498		
Overall Length	B	4782	5182		
Overall Height	C	1959*/1965**	2492	1958	2492
Overall Width	D	1904			
Sill Height	E	543*/549**	547	542	548
Cargo Length	F	2400		2800	
Cargo Height	G	1387	1887	1387	1887
Cargo Width	H	1668			
Width between wheel arches	I	1268			

*1.0 tonne payload models
**1.2 tonne payload models

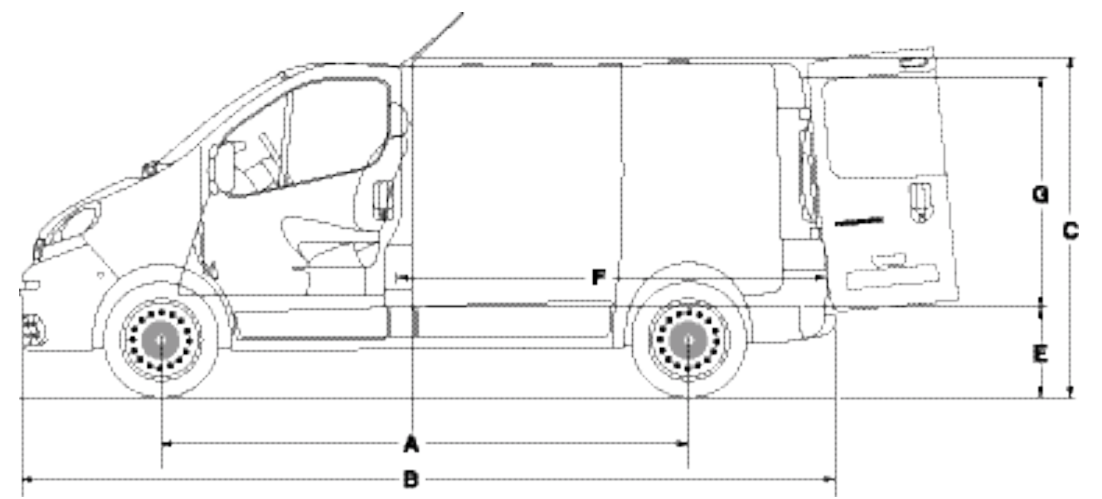

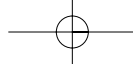

Polar White

Z 36 **S**



Furnace Red

Z 35 **S**



Delta Blue

Z 39 **S**



Solar Yellow

Z 37 **S**

S solid

M metallic



Universe Black

Z 41 **M**



Hydra Green

Z 42 **M**



Rascasse Red

Z 56 **M**



Mercury Silver

Z 34 **M**



Delft Blue

Z 46 **M**

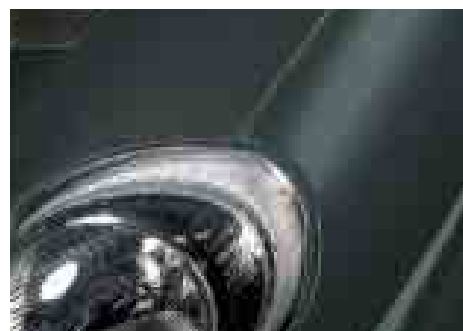

Expedition Green

Z 55 **M**



Sand Dune

ZW 5 **M**

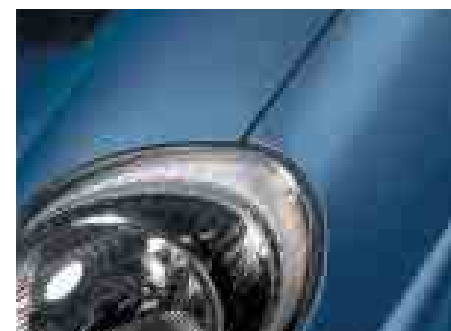

Panorama Blue

ZW 6 **M**



Interior Fabric

TRIM AND COLOURS

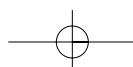

TECHNICAL SPECIFICATIONS VANS

Model		PRIMASTAR								
Length		Short Wheel Base				Long Wheel Base				
Roof Height		Low			High	Low		High		
Engine		dCi80	dCi100	dCi100	dCi135	dCi100	dCi100	dCi135	dCi100	dCi135
Payload		Low		High	Low	High	High			
ENGINE										
No. of Cylinders		4				4				
Valves per Cylinder		2		4	2	2	4	2	4	
Engine Capacity		cm ³		1870	2464	1870	1870	2464	1870	2464
Bore x Stroke		mm		80x93	89x99	80x93	80x93	89x99	80x93	89x99
Maximum Engine Power		hp	82	100	135	100	100	135	100	135
		rpm	3500				3500			
Maximum Torque		Nm	190	240	310	240	240	310	240	310
		rpm	2000		1750	2000	2000	1750	2000	1750
Compression Ratio		18.3:1		18:1	18.3:1	18.3:1	18:1	18.3:1	18:1	
Fuel Type		Diesel				Diesel				
Fuel supply		Direct Common Rail								
Battery		Ah	70				70			
Alternator		Amps	125		110	125	125	110	125	110
DRIVE TRAIN										
Transmission		dCi80: 5 speed manual, dCi100 and dCi135: 6 speed manual								
Driven Wheels		Front								
CHASSIS										
Suspension		Front	Independent, McPherson strut, coil springs, anti-roll bar							
		Rear	Torsion beam axle, coil springs with progressive action, shock absorbers with variable damping and anti-roll bar							
Steering		Rack and pinion, power assisted								
Braking System (option)		Ventilated disc front : 305" / 28mm, solid disc rear : 280" / 12mm, (ABS with EBD)								
Wheel Size		6 J 16								
Tyre Size		Payload 1000: 195/65R16C / Payload 1200: 205/65R16 C Standard on dCi135: 215/65R16 (not available for L2 version)								
FUEL CONSUMPTION*										
Fuel Consumption EEC 00/100		Urban Cycle	mpg	30.4	27.7	30.4	30.4	27.4	29.4	27.4
			l/100 km	9.3	10.2	9.3	9.3	10.3	9.6	10.3
		Extra-Urban	mpg	41.5	37.2	41.5	41.5	36.7	40.9	36.7
			l/100 km	6.8	7.6	6.8	6.8	7.7	6.9	7.7
		Combined	mpg	36.7	33.2	36.7	36.7	32.8	35.8	32.8
			l/100 km	7.7	8.5	7.7	7.7	8.6	7.9	8.6

* Manufacturer's own figures

Model		PRIMASTAR									
Length		Short Wheel Base				Long Wheel Base					
Roof Height		Low			High	Low		High			
Engine		dCi80	dCi100	dCi100	dCi135	dCi100	dCi100	dCi135	dCi100	dCi135	
Payload		Low		High	Low	High	High				
PERFORMANCE											
Maximum Speed		km/h	138	155	163	144	155	163	144	154	
		mph	85.7	96.3	101.3	89.5	96.3	101.3	89.5	95.7	
Min. Turning Circle (Kerb to Kerb)		m	11.8				13.2				
WEIGHTS											
Kerb Weight		Min.	kg	1677	1684	1745	1754	1728	1794	1808	1881
Gross Vehicle Weight		kg	2700	2900	2760	2900	2940	3030	2990	3015	
Maximum Payload *		kg	1023	1216	1015	1146	1212	1236	1182	1134	
Gross Axle Weight		Front	kg	1450	1550	1450	1550	1550		1580	
		Rear	kg	1550	1650	1550	1650	1650			
Max. Trailer Cap. ¹⁾		Braked	kg	2000				2000			
		Unbraked	kg	750				750			
OVERALL DIMENSIONS											
Length		mm	4782				5182				
Width		mm	1904								
Height (unladen)		Min.	mm	1959	1965	1959	2492	1958		2492	
Wheelbase		mm	3098				3498				
Overhang		Front	mm	833							
		Rear	mm	851							
Track		Front	mm	1615							
		Rear	mm	1630							
Ground Clearance (unladen)		mm	185	185	193	188	188	187	187		
CARGO AREA DIMENSIONS											
Maximum Length		mm	2400				2800				
Maximum Width		mm	1668								
Maximum Height		mm	1387			1913	1387		1913		
Minimum Width Between Wheelarches		mm	1268								
Max. Load Platform Height		mm	543	549	543	547	542	548			
Cargo Volume		m ³	5.02			7.09	5.93		8.36		
Side Door		Width	mm	1000							
		Height	mm	1285							
Back Door		Width	mm	1414							
		Height	mm	1335		1818	1335		1818		
FUEL TANK											
Capacity		l	90								

* GVW minus unladen weight (driver and crew weight must be subtracted).

¹⁾ When a vehicle is fitted with a towbar, it is recommended that a tachograph is fitted, since the ability to tow a trailer giving a Gross Train Weight (GVW + Trailer Weight) of over 3,500Kg without a tachograph could be considered to be contrary to EU and UK road traffic legislation.

PRIMASTAR STANDARD EQUIPMENT

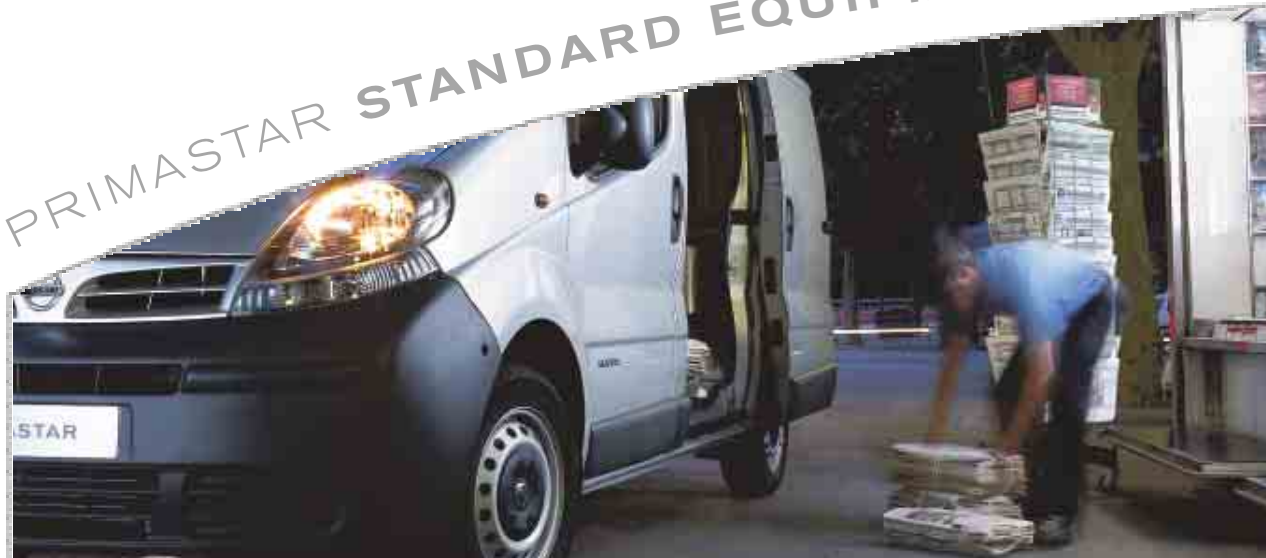

E

CARGO AREA ACCESSIBILITY

- Unglazed 180° opening rear doors
- Near side sliding load door
- Side and rear door activated loading lamps
- 6 x floor mounted lashing rings

SAFETY

- Driver Airbag
- 3-point seatbelts (x2)
- Seatbelt pre-tensioners
- High mounted rear stop lamp
- 1/3 tubular bulkhead behind driver
- Panoramic door mirrors
- Side impact door bars
- 4 disc brakes (ventilated front)

SECURITY

- Engine Immobiliser
- Superlocking

COMFORT AND CONVENIENCE

- Three-way adjustable driver's seat
- Single passenger seat
- Remote central door locking
- Tinted windows
- Power assisted steering
- RDS Radio Cassette
- Steering wheel audio controls
- Tachometer

- Intermittent wash-wipe (windscreen)
- Map lamp
- Dash-mounted gear lever
- Driver & passenger cup holders
- Door pocket with large bottle holder
- Glove box with cassette and sunglasses holder

SE

AS E PLUS

- ABS
- Full steel bulkhead
- Perimeter and volumetric alarm
- Power windows
- Power and heated door mirrors
- Twin passenger seat with additional 3-point seatbelt
- Nissan Rear Park System (RPS)
- CD Radio (i.l.o. Radio cassette)

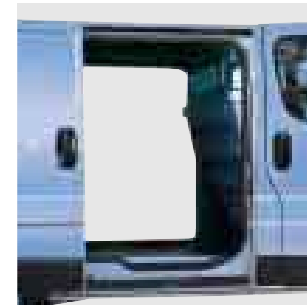

SECOND SLIDING DOOR

An option in addition to the standard kerbside sliding door.

You can also order the Primastar without any sliding side doors.



GLAZED PARTITION AND HEATED REAR WINDOWS WITH WASH-WIPE

Offers the convenience of a rear view combined with a strong, noise-reducing barrier.



TAILGATE

This high-opening tailgate makes it easier and more comfortable to unload on rainy days.



AIR CONDITIONING

Helps to keep you fresh and alert at the wheel and makes your passengers more comfortable too.



ANTI-LOCK BRAKES (ABS)

ABS combined with standard discs.



CD WITH 4 SPEAKERS

In place of the standard radio cassette, CD radio can be selected.

Every business is different. So we offer a range of options for alternative load carrying, extra comfort and more convenience. Please contact your dealer for the full list of all options available. The Primastar is also ideal for bodies custom-built for a specific purpose and your Nissan dealer will be pleased to recommend converters and bodybuilders who can undertake your desired conversion.

PRIMASTAR OPTIONS